



Analysis Predictors of the Outcome of Adjuvant of Hormone Therapy on Estrogen Receptor-positive Breast Cancer in Indonesia

Hardisman Dasman^{1*}, Wirsma Arif Harahap², Daan Khambri³

¹Department of Public Health and Community Medicine, Faculty of Medicine, Andalas University, Padang, Indonesia;

²Department of Surgery, Division of Surgical Oncology, Faculty of Medicine, Andalas University, M Djamil General Hospital, Padang, Indonesia; ³Department of Surgery, Division of Surgical Oncology, Faculty of Medicine, Andalas University, M Djamil General Hospital, Padang, Indonesia

Abstract

BACKGROUND: An existing study reported variation of the outcome of adjuvant hormone therapy on breast cancer.

AIM: This study aimed to examine predictors of the hormone therapy to the outcome of recurrence-free survival (RFS) of estrogen receptor-positive (ER+) breast cancer.

METHODS: In this cohort study, we followed up 219 eligible breast cancer patients with ER+ who had hormone therapy in 2017–2018. Age of patients, cancer stage, and various histopathology parameters were collected from the medical records, then we followed up with the patients within 2 years (2019–2020) to assess the RFS outcome. Bivariate analysis was conducted to assess the association between the clinicopathology parameters with RFS outcome. Multivariate analysis with logistic regression was also performed to see the dominant predictor. Mediation path analysis was also performed to determine the estimated effect of a predictor on the level of RFS and to see the visualization of the association of predictors with RFS.

RESULTS: Breast cancer RFS was 91.3% within 2 years of hormone therapy. The recurrent rate was only 8.7%, which most of them (68.4%) were local. There was no association of age, lymphovascular invasion (LVI), progesterone receptor (PR), and human epidermal growth factor receptor 2 (HER2) status with RFS. Based on the molecular subtype, the RFS was better in luminal A ($p = 0.045$), and also better gradually in the lower stage ($p = 0.001$). Multivariate analysis shows that the cancer stage was the dominant predictor of the RFS outcome ($p = 0.001$) with OR = 4.271 (Exp[B] = 1.937–9.417). Mediation analysis also found that there was a positively associated molecular subtype with RFS through cancer stage mediation ($r = 16.7\%$, $p = 0.006$) but no statistically significant association of age, LVI, PR, and HER2 status ($p > 0.005$).

CONCLUSION: Cancer stage is the main predictor of RFS of hormone therapy outcome. Luminal A is most also likely to have a better outcome of RFS, especially mediated by the lower stage.

Edited by: Ksenija Bogoeva-Kostovska
Citation: Dasman H, Harahap WA, Khambri D. Analysis Predictors of the Outcome of Adjuvant of Hormone Therapy on Estrogen Receptor-positive Breast Cancer in Indonesia. Open Access Maced J Med Sci. 2021 Aug 28; 9(B):847-851. https://doi.org/10.3889/oamjms.2021.6683
Keywords: Breast cancer; Outcome; Recurrence; Recurrent free survival
***Correspondence:** Dr. Hardisman Dasman, Department of Public Health and Community Medicine, Faculty of Medicine, Andalas University, Padang, Indonesia. E-mail: hardisman@med.unand.ac.id
Received: 21-Jun-2021
Revised: 27-Jul-2021
Accepted: 18-Aug-2021
Copyright: © 2021 Hardisman Dasman, Wirsma Arif Harahap, Daan Khambri
Funding: This research did not receive any financial support
Competing Interests: The authors have declared that no competing interests exist
Open Access: This is an open-access article distributed under the terms of the Creative Commons Attribution-NonCommercial 4.0 International License (CC BY-NC 4.0)

Introduction

Breast cancer is the most prevalent cancer among women in the world, and also one of the main causes of death [1], [2], [3]. Breast cancer is also the most prevalent in women in Indonesia, which is recorded about 30.8%, and also the most common cancer-related mortality cause among women in the country (WHO, 2020).

The cancers can be classified into molecular subtypes, including luminal A, luminal B, human epidermal growth factor receptor 2 (HER2+), and triple-negative (TN) [4], [5]. Luminal A breast cancer is a cancer type with hormone-receptor positive, either estrogen receptor (ER) or progesterone receptor (PR) positive, HER2 negative, and has low level of the protein Ki-67. The luminal A type is a low-grade and tend to grow slowly and have the best prognosis. Luminal B breast cancer is a cancer type hormone-receptor positive and either HER2 positive or negative

with high level of Ki-67. Luminal B cancers grow slightly faster than luminal A cancers. TN or basal-like breast cancer is hormone-receptor (ER and PR) negative and HER2 negative. HER2-enriched non-luminal is ER and PR negative and HER2 positive. HER2-enriched cancers tend to grow faster than luminal cancers and can have a worse prognosis. However, HER2 cancers are more successfully treated with targeted therapy for HER2 protein. Clinical courses, patterns of metastasis, and outcome and prognosis may also vary among these subgroups [4], [5]. The recurrence mostly happens during the first 5 years after treatment among all subtypes. However, late recurrence may also occur, such as in the luminal subtype with HER2 negative and PR-positive [6]. The recurrence may increase in cancer with high staging and HER2 positive, and inverse with the ER and PR status [7].

Some breast cancers are growing sensitive to female body hormones, estrogen and progesterone, in which breast cancer cells have receptors that can interact with those hormones in the circulation. From

the expression of the hormone receptors, breast cancer can be ER positive (ER+) and progesterone positive (PR+), or ER- and PR-. The ER+ is a type of breast cancer that has receptors that are stimulated to grow by estrogen hormone, and PR+ is a type of breast cancer that has PR and sensitive to progesterone to grow [8].

Treatment of ER+ type is with anti-estrogen hormone therapy can block the growth of the cancer cells. Few groups of hormonal therapy may be used, including selective estrogen-receptor response modulators (such as tamoxifen and toremifene), aromatase inhibitors that stop the production of estrogen by blocking the enzyme aromatase (such as anastrozole, exemestane, and letrozole), estrogen-receptor downregulators that block the effects of estrogen in breast tissue (such as fulvestrant), and luteinizing hormone-releasing hormone agents that stop the ovaries from producing estrogen (such as goserelin and leuprolide) [8]. Many studies suggested that the patients who have adjuvant hormone therapy had a better outcome, with low recurrence [9], [10].

Outcome and recurrence of breast cancer associate with the cancer clinicopathology features and treatment [11]. The existing publications on breast cancer recurrence were limited and heterogeneous [12]. The increasing of invasive cancer tended to have a higher risk of recurrence [13]. Lafourcade *et al.* [14] also reported that low survival of breast cancer was associated with high grade of the tumor, large size, and negative estrogen, and PRs. However, the result may vary among studies [11], [15]. Specifically, the response to hormone therapy in ER+ breast cancer also varied among other parameters, such as in PR- the outcome was low [16].

Due to variation of studies on the possible outcome and inadequate report in the Indonesian context, in this study, we had to explore predictors of the outcome of hormone therapy in ER+ breast cancer in the country, by considering other clinicopathology parameters.

Materials and Methods

Study design and research sample

This research was quantitative research with a cross-sectional prospective design. The subjects of the study were breast cancer patients with ER+ who had adjuvant hormone therapy in 2017–2018. The initial clinicopathology data were collected during treatment which were recorded in the medical record.

The follow-up has been conducted with 2 years of the treatment to assess the outcome or event of recurrence of the disease. The 2 years of follow-up were very feasible to be conducted due to the relatively

short period. Within 2 years after treatment, breast cancer is more likely to have an initial recurrence.

The subjects of the study were collected from three hospitals in Padang City, West Sumatera Province of Indonesia, which were M Djamil General Hospital, YARSI Hospital, and Ropanasuri Surgical Hospital, which had experts and facilities for definitive treatment for breast cancer. Within 2 years of follow-up, 219 cases were eligible for the study with completed clinicopathology data. All patients in the study were funded under the national health insurance scheme for their treatment.

Operational definitions

The variables of this study included age, cancer stage, lymphovascular invasion (LVI) status, PR Expression, HER2 status, and molecular subtype as independent variables. For bivariate analysis, all those variables were measured in categorical data.

The dependent variable was recurrence-free survival (RFS) for measuring the outcome. The recurrence was measured by any signs in clinical examination, which was performed by the clinician expert within 2 years of follow-up. The recurrence was included local or regional and distant recurrence. Local recurrence was cancer that was back in the same place it first started, while regional recurrence means the cancer was back in the lymph nodes near the place it first started, and distant recurrence means the cancer was back and growing in another part of the body, such as lungs, liver, bone, or brain. Cancer survival means that there were no signs of any recurrence either local or regional and distance during the follow-up.

Data collection technique and analysis

The clinicopathology data including age, cancer stage, LVI status, PR, HER2, and molecular subtype were collected during the patients' treatment by the clinicians who were also part of the research team. The data were written and available in the medical record. Within 2 years, the clinicians and the researchers followed up on the patient's condition. The followed-up mostly focus on any signs of recurrence, either local or regional and distance.

Univariate, bivariate, and multivariate analyses were performed to answer the research questions and to draw a conclusion. Univariate analysis was to see the proportion of cases in each pathology parameter and the outcome within 2 years. Bivariate analysis by conducting Chi-square with correction and Fisher's exact test was done to examine the association of clinicopathology to the outcome. Later logistic regression was performed to determine the dominant factor associated with the survival outcome.

Mediation path analysis was performed to determine the estimated effect of a predictor on the level of RFS. The mediation analysis also explores any direct and indirect effect of other parameters through mediation predictor, and as well as see the visualization of association of predictors with RFS.

Results

The samples of the study were mostly with age <55 years old (pre-menopause) (63.5%). The clinicopathology was majority invasive non-specific subtype (51.5%), LVI negative (-) (84.0%), PR positive (+) (82.2%), and HER2 negative (70.3%). Meanwhile, the cancer staging was range from Stage I to IV, with equally distributed Stage IIA (27.4%), IIB (23.3%), and IIIB (27.4%) (Table 1).

Table 1: Characteristics of breast cancer in the study

Characteristics	Category	f (n = 219)	%
Age	<55	139	63.5
	>55	80	36.5
Histopathology Subtype	Invasive non-specific type	112	51.1
	Invasive ductal	44	20.1
	Invasive lobular	36	16.4
	Invasive mucinous	13	5.9
	Mix type	4	1.8
	Others	10	4.6
LVI	Negative	184	84.0
	Positive	35	16.0
PR	Negative	39	17.8
	Positive	180	82.2
HER2	Negative	154	70.3
	Positive	65	29.7
Molecular Subtype	Luminal A	80	36.5
	Luminal B	139	63.5
Stage	I	8	3.7
	IIA	60	27.4
	IIB	51	23.3
	IIIA	27	12.3
	IIIB	60	27.4
	IIIC	2	0.9
IV	11	5.0	

LVI: Lymphovascular invasion, PR: Progesterone receptor, HER2: Human epidermal growth factor receptor 2.

Breast cancer RFS was 91.3% within 2 years of follow-up after hormonal therapy, with a recurrent rate of 8.7%. Out of 19 cases of recurrence, the majority of them (68.4%) were local recurrence (Table 2).

Table 2: Outcome therapy

Outcome	f	%
RFS (n = 219)		
Yes (survive)	200	91.3
No (recurrent)	19	8.7
Recurrent (n = 19)		
Local	13	68.4
Distance	6	31.6

RFS: Recurrence-free survival.

Breast cancer RFS within 2 years of adjuvant hormone therapy was slightly lower in age <50 (89.2%) than >50 years old (95.0%), but it was not statistically significant (p = 0.143). The cancer RFS was comparable between LVI status negative (91.3%) and positive (91.4%) (p = 0.981), PR negative (92.3%) and positive (91.1%) (p = 0.810), and HER2 negative (90.9%) and positive (92.3%) (p = 0.737). According to the molecular subtype, the RFS was better in luminal A (96.3%) than

luminal B (88.5%) (p = 0.045). The cancer RFS was also better gradually in the lower stage (p = 0.001) (Table 3).

Table 3: Bivariate analysis association of predictors with the outcome

Variable	Category	Survive (f, %)	Recurrence (f, %)	p-value
Age	<55	124 (89.2)	15 (10.8)	0.143
	>55	76 (95.0)	4 (5.0)	
LVI	Negative	168 (91.3)	16 (8.7)	0.981
	Positive	32 (91.4)	3 (8.6)	
PR	Negative	36 (92.3)	3 (7.7)	0.810
	Positive	164 (91.1)	16 (8.9)	
HER2	Negative	140 (90.9)	14 (9.1)	0.737
	Positive	60 (92.3)	5 (7.7)	
Molecular Type	Luminal A	77 (96.3)	3 (3.8)	0.045
	Luminal B	123 (88.5)	16 (11.5)	
Stage	I	8 (100.0)	0 (0.0)	0.001
	II	106 (95.5)	5 (4.5)	
	III	81 (91.0)	8 (9.0)	
	IV	5 (45.5)	6 (54.5)	

LVI: Lymphovascular invasion, PR: Progesterone receptor, HER2: Human epidermal growth factor receptor 2.

Regression multivariate analysis shows that the staging was the dominant predictor of the outcome (p = 0.001). The cancer staging positively associates with the RFS with OR = 4.271 (Exp[B] = 1.937–9.417), which lower staging cancer tended to have better survival outcomes. Overall, all predictors that have been analyzed affected the RFS 22.1% (R-square) (Table 4).

Table 4: Multivariate analysis of determinant predictor to the outcome

Predictor	B	p	Exp(B) (95% CI)	R-square
Age	-0.909	0.136	(NA)	0.221
Molecular subtype	1.048	0.117	(NA)	
Staging	1.452	0.001	4.271 (1.937–9.417)	

Further analysis in exploring the effect of other predictors on the level of recurrence was examined by mediation analysis. The study found that there was no statistically significant association of age, LVI, PR, and HER2 status with RFS through cancer stage mediation (p > 0.005). The study also found that molecular subtype positively associates with RFS (r = 16.7%), which means Category 1 (luminal A) had a better outcome than luminal B (p = 0.006) (Table 5). The completed model is seen in Figure 1.

Table 5: Total effect through cancer stage mediation

Predictor	Estimated Effect (95%CI)	p-value
Age-(stage)->Recurrence	-0.083 (-0.193–0.027)	0.140
LVI-(stage)->Recurrence	0.037 (-0.105–0.180)	0.609
PR-(stage)->Recurrence	0.018 (-0.118–0.154)	0.798
HER2-(stage)->Recurrence	-0.110 (-0.241–0.021)	0.100
Mol. Subtype -(stage)->Recurrence	0.167 (0.047–0.288)	0.006

LVI: Lymphovascular invasion, PR: Progesterone receptor, HER2: Human epidermal growth factor receptor 2.

Discussion

Breast cancer RFS was 91.3% within 2 years of follow-up after hormonal therapy, with a recurrent rate of 8.7%. Out of 19 cases of recurrence, the majority of them (68.4%) were local recurrence. This study revealed that the RFS of breast cancer after adjuvant hormone therapy was relatively better than the overall

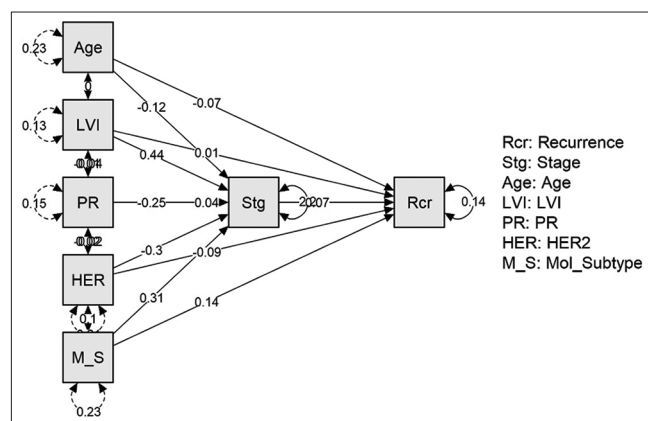

Figure 1: Mediation model of effect predictor to breast cancer recurrence

RFS of breast cancer in other studies. A meta-analysis study found that the recurrence rate of breast cancer was 17.2% on average [15]. The hazard of recurrence within 5 years of therapy was 10.4% annually, with the highest in the 1st and the 2nd year (15.2%) [17]. Our finding suggests that hormonal therapy decreases the recurrence rate. Moreover, overall breast cancer tended to have predominantly distant recurrence [18], [19]. By contrast, our study found that breast cancer with hormonal therapy mostly has a local recurrence. The finding implies that hormonal therapy had benefits for both recurrent rate and the level of recurrence.

Breast cancer RFS within 2 years of adjuvant hormone therapy was slightly lower in age <50 (89.2%) than >50 years old (95.0%), but it was not statistically significant ($p = 0.143$). This can be an effect of the activity of hormone physiology, in which women at younger age normally have more estrogen production than the menopause age. The effect of hormone therapy as antiestrogen might be slightly lower despite not being statistically significant. This finding is supported by others studies, which reported that the risk of recurrence is higher at a young age [20], and needs more aggressive therapy [21].

The breast cancer stage associates with the RFS, that the lower stage cancer has a better outcome ($p=0.001$). The cancer stage is also the dominant predictor to the hormone therapy outcome with $OR=4.271$ ($Exp[B]=1.937-9.417$). Low stage of cancer is most likely to have little tumor size and less lymph node involved, which have a better result of definitive therapy and low recurrence. The finding supports existing study in overall breast cancer outcome, that the cancer stage is one of the important determinants to survival [7].

According to the molecular subtype, the RFS was better in luminal A (96.3%) than luminal B (88.5%) ($p = 0.045$). Mediation path analysis also shows that molecular subtype positively associates with RFS ($r = 16.7\%$), which means luminal A most also likely to have a better outcome of RFS, especially mediated by the lower stage. This finding is consistent with other studies

in overall cases of breast cancer that reported luminal A has low early recurrence [22]. Physiologically luminal A breast cancer has slower growth than the others [4], [5], and hormone therapy does not affect other parameters for classified into molecular subtype.

Conclusion

Breast cancer with ER+, which had hormone therapy, relatively has a better RFS and low recurrent rate, and as well as low risk to have a distant recurrence. The cancer stage is the main predictor of RFS, which the lower stage predominantly has a better hormone therapy outcome. Breast cancer with luminal A subtype is most likely to have a better outcome, especially mediated by the lower stage.

Author Declaration of Contribution

All authors (HD, WAH, and DK) equally contributed to developing the research, and for the final revision of the article. WAH was the main responsible for collecting the data, and HD was responsible for data analysis and initial drafting of the manuscript.

Acknowledgments

The author would like to thank all clinicians and nurses who helped to collect and recording the necessary data in the breast cancer database. The authors also thank Wiwin Susilawati, BA, for proof-read the manuscript.

References

1. Bray F, Ferlay J, Soerjomataram I, Siegel RL, Torre LA, Jemal A. Global cancer statistics 2018: GLOBOCAN estimates of incidence and mortality worldwide for 36 cancers in 185 countries. *CA Cancer J Clin.* 2018;68(6):394-424. <https://doi.org/10.3322/caac.21492>
PMid:30207593
2. Momenimovahed Z, Salehiniya H. Epidemiological characteristics of and risk factors for breast cancer in the world. *Breast Cancer.* 2019;11:151-64. <https://doi.org/10.2147/bctt.s176070>
PMid:31040712
3. Torre LA, Islami F, Siegel RL, Ward EM, Jemal A. Global cancer

- in women: Burden and trends. *Cancer Epidemiol Biomarkers Prev.* 2017;26(4):444-57. <https://doi.org/10.1158/1055-9965.epi-16-0858>
PMid:2822343
4. National Cancer Institute. Cancer Stat Facts: Female Breast Cancer Subtypes; 2020. Available from: <https://www.seer.cancer.gov/statfacts/html/breast-subtypes.html>. [Last accessed on 2021 Feb 20]. <https://doi.org/10.32388/7sm165>
 5. Tan PH, Ellis I, Allison K, Brogi E, Fox SB, Lakhani S, et al. The 2019 World Health Organization classification of tumours of the breast. *Histopathology.* 2020;77(2):181-5. <https://doi.org/10.1111/his.14091>
PMid:32056259
 6. Nishimura R, Osako T, Nishiyama Y, Nakano M, Fujisue M, Toyozumi Y, et al. Evaluation of factors related to late recurrence-later than 10 years after the initial treatment-in primary breast cancer. *Oncology.* 2013;85(2):100-10. <https://doi.org/10.1159/000353099>
PMid:23867253
 7. Harahap WA, Nindrea RD. Prognostic Factors of local-regional recurrence in patients with operable breast cancer in Asia: A meta-analysis. *Open Access Maced J Med Sci.* 2019;7(4):690-5. <https://doi.org/10.3889/oamjms.2019.151.151>
PMid:30894935
 8. National Cancer Institute. Breast Hormone Therapy Fact Sheet. Available from: <https://www.cancer.gov/types/breast/breast-hormone-therapy-fact-sheet>. [Last accessed on 2021 Feb 20]. <https://doi.org/10.1037/e533512012-001>
 9. Davey MG, Ryan EJ, McAnena PF, Boland MR, Barry MK, Sweeney KJ, et al. Disease recurrence and oncological outcome of patients treated surgically with curative intent for estrogen receptor positive, lymph node negative breast cancer. *Surg Oncol.* 2021;37:101531. <http://doi.org/10.1016/j.suronc.2021.101531>
PMid:33545657
 10. Rugo HS, Finn RS, Gelmon K, Joy AA, Harbeck N, Castellon A, et al. Progression-free survival outcome is independent of objective response in patients with estrogen receptor-positive, human epidermal growth factor receptor 2-negative advanced breast cancer treated with palbociclib plus letrozole compared with letrozole: Analysis from PALOMA-2. *Clin Breast Cancer.* 2020;20(2):e173-80. <https://doi.org/10.1016/j.clbc.2019.08.009>
PMid:31836434
 11. De-Angelis C, Nagi C, Hoyt CC, Liu L, Roman K, Wang C, et al. Evaluation of the predictive role of tumor immune infiltrate in patients with her2-positive breast cancer treated with neoadjuvant anti-HER2 therapy without chemotherapy. *Clin Cancer Res.* 2020;26(3):738-45. <https://doi.org/10.1158/1078-0432.ccr-19-1402>
PMid:31653641
 12. Izci H, Tambuyzer T, Tuand K, Depoorter V, Laenen A, Wildiers H, et al. A systematic review of estimating breast cancer recurrence at the population level with administrative data. *J Natl Cancer Inst.* 2020;112(10):979-88. <https://doi.org/10.1093/jnci/djaa050>
PMid:32259259
 13. Schunkert EM, Zhao W, Zänker K. Breast cancer recurrence risk assessment: Is non-invasive monitoring an option? *Biomed Hub.* 2018;3(3):1-17. <https://doi.org/10.1159/000492929>
PMid:31988964
 14. Lafourcade A, His M, Baglietto L, Boutron-Ruault M, Dossus L, Rondeau V, et al. Factors associated with breast cancer recurrences or mortality and dynamic prediction of death using history of cancer recurrences: The French E3N cohort. *BMC Cancer.* 2018;18(1):171. <https://doi.org/10.1186/s12885-018-4076-4>
PMid:29426294
 15. Salvo E, Ramirez AO, Cueto J, Law EH, Situ A, Cameron C, et al. Risk of recurrence among patients with HR-positive, HER2-negative, early breast cancer receiving adjuvant endocrine therapy: A systematic review and meta-analysis. *Breast.* 2021;57:5-17. <https://doi.org/10.1016/j.breast.2021.02.009>
PMid:33677313
 16. Van Mackelenbergh MT, Denkert C, Nekljudova V, Karn T, Schem C, Marmé F, et al. Outcome after neoadjuvant chemotherapy in estrogen receptor-positive and progesterone receptor-negative breast cancer patients: A pooled analysis of individual patient data from ten prospectively randomized controlled neoadjuvant trials. *Breast Cancer Res Treat.* 2018;167(1):59-71. <https://doi.org/10.1007/s10549-017-4480-5>
PMid:28875243
 17. Colleoni M, Sun Z, Price KN, Karlsson P, Forbes JF, Thürlimann B, et al. Annual hazard rates of recurrence for breast cancer during 24 years of follow-up: Results from the international breast cancer study group trials I to V. *J Clin Oncol.* 2016;34(9):927-35. <https://doi.org/10.1200/jco.2015.62.3504>
PMid:26786933
 18. Geurts YM, Witteveen A, Bretveld R, Poortmans PM, Sonke GS, Strobbe LJ, et al. Patterns and predictors of first and subsequent recurrence in women with early breast cancer. *Breast Cancer Res Treat.* 2017;165(3):709-20. <https://doi.org/10.1007/s10549-017-4340-3>
PMid:28677011
 19. Li Y, Lu S, Zhang Y, Wang S, Liu H. Loco-regional recurrence trend and prognosis in young women with breast cancer according to molecular subtypes: Analysis of 1099 cases. *World J Surg Oncol.* 2021;19:113. <https://doi.org/10.21203/rs.3.rs-62351/v2>
PMid:33849563
 20. He XM, Zou DH. The association of young age with local recurrence in women with early-stage breast cancer after breast-conserving therapy: A meta-analysis. *Sci Rep.* 2017;7:11058. <https://doi.org/10.1038/s41598-017-10729-9>
PMid:28894168
 21. Lee MK, Varzi LA, Chung DU, Cao M, Gornbein J, Apple SK, et al. The effect of young age in hormone receptor positive breast cancer. *Biomed Res Int.* 2015;2015:325715. <https://doi.org/10.1155/2015/325715>
PMid:26351632
 22. Yu NY, Iftimi A, Yau C, Tobin NP, van 't Veer L, Hoadley KA, et al. Assessment of long-term distant recurrence-free survival associated with tamoxifen therapy in postmenopausal patients with luminal a or luminal B breast cancer. *JAMA Oncol.* 2019;5(9):1304-9. <https://doi.org/10.1001/jamaoncol.2019.1856>
PMid:31393518